

Operating manual

High-pressure cleaners

B 170 T
B 200 T
B 230 T
B 240 T
B 270 T



Read and conform safety instructions before use!

Keep instructions in a safe place for later use and pass them on to any future user.



Description

Dear customer

We would like to congratulate you on your new mobile high pressure cleaner and to thank you for the purchase.

To ease your introduction to the use of the cleaner, we have provided the following pages of explanations, tips and hints, which we ask you to read before using for the first time.

The equipment will assist you professionally in all cleaning tasks, e.g.:

- facades
- vehicles of all types
- barrels and containers
- flagstones
- sheds
- channels
- terraces
- machines etc.
- Streets etc.

Technical data	B 170 T	B 200 T	B 240 T	B 270 T	B 230 T Spec. appliance
Operating pressure, steplessly adjustable	10 - 150 bar	10 - 165 bar	10 - 220 bar	10 - 250 bar	10 - 200 bar
Perm. overpressure	165 bar	180 bar	240 bar	270 bar	230 bar
Water output ^(*) at 1800 rpm	13 l/min	12 l/min	16 l/min	16 l/min	20 l/min
Hot water input	70 °C	70 °C	70 °C	70 °C	50 °C
Suction height	2,5 m	2,5 m	2,5 m	2,5 m	2,5 m
High pressure hose with hose drum	20 m GX 160 LX2	20 m GX 200 LX2	20 m GX 340 LX2	20 m GX 390 LX2	20 m GX 390 LX2
Combustion motor Honda	58 kg	58 kg	83kg	83 kg	83 kg
Weight	103 dB (A)	103 dB (A)	103 dB (A)	103 dB (A)	103 dB (A)
Sound level Guaranteed sound level L _{WA}	appr. 32 Nm	appr. 27 Nm	appr. 38 Nm	appr. 42 Nm	appr. 42 Nm
Recoil at lance	29 Nm	24,3 Nm	33 Nm	36 Nm	36 Nm
Torque	(Assumed length of lance: 0,9 m)				
Order n°:	41 190 1	41 191 1	41 192 1*	41 193 1*	41 194 1*

with speed control *

Permissible tolerance for figures ± 5 % in acc. with VDMA uniform sheet 24411

^(*) Minimum quantity of water to be led to the equipment!

Description



Construction

The KRÄNZLE B170 T + B200 T + B230 T+ B240 T + B270 T - high pressure cleaners are mobile machines. The design can be seen from the diagram.

Item

- 1 Water inlet connection with filter
- 2 Suction hose with filter (special accessory) Order no. 15.038 3
- 3 High pressure pump
- 4 Press. gauge with glycerin filling

- 5 Unloader valve - safety valve
- 6 High pressure hose
- 7 Spray gun
- 8 Interchangeable lance with high pressure nozzle

Description

Water and Cleaning / Pflegemittel System

Water can be connected at mains pressure to the high pressure pump or it can be sucked directly from a storage tank. The water is then forced under pressure by the high pressure pump to the lance. The high pressure jet is formed by the nozzle at the end of the lance.

Detergent and caring agents can be added through a high pressure injector (special accessory). Up to max 20m HP hose length. The rules concerning the environment, refuse and ground water protection must be complied with!
(Information to be obtained from environmental dept, town works, etc.)



Lance with trigger gun

The machine can only be operated when the safety trigger is squeezed. The machine can only be operated when the safety trigger is squeezed.

When the lever is squeezed, the spray gun opens. The liquid is then pumped to the nozzle. The spray pressure increases and quickly reaches the selected operating pressure.

When the trigger is released, the trigger gun closes and any further spraying of liquid from the lance is stopped.

The increase in pressure when the trigger gun is closed causes the unloader valve-safety valve to open. The pump remains switched on and continues to pump liquid through the pump at reduced pressure. When the trigger gun is opened, the unloader valve - safety valve closes and the pump resumes pressure spraying from the lance

The trigger gun is a safety device. Repairs should only be performed by qualified persons. Should replacement parts be required, use only components authorized by the manufacturer.



Unloader valve - safety valve

The unloader valve - safety valve protects the machine from a build up of excess pressure, and is designed not to permit an excess pressure to be selected for operation. The limit nut on the handle is sealed with a spray coating.

The operating pressure and spray rate can be steplessly adjusted by turning the handle.

Replacements, repairs, new adjustments and sealing should only be performed by qualified persons.



Description

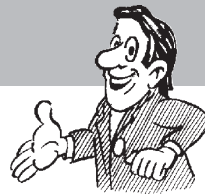

For the motor follow the Honda operating manual only.

Motor-safety: (see Honda operating manual)

Honda motors are safe and reliable if they are operated correctly. Read the operating manual carefully before using the motor and try to understand the contents of the manual completely.

Not following this advice could lead to injuries or damage of the equipment.

To avoid a possible fire hazard and to ensure the necessary ventilation the motor has to be operated at a distance of at least 1 m from buildings and objects. Inflammable objects have to be kept away from the surrounding area of the motor.



Children and pets have to be kept away from the motor, as there is a danger of suffering burns from hot motor parts and to be injured by equipment driven by the motor.

Get to know the motor and especially learn how to switch it off quickly. Do not allow persons to operate the motor who are not familiar with it.

Setting up: Location



Neither set up and operate the machine in rooms where there is a risk of fire or explosion nor put it into puddles. Do not use the machine under water.

Do NOT !! tilt or turn round the high-pressure cleaner during transport or operation for longer than 1 minute!

CAUTION !

Never use liquid containing solvents such as paint thinners, petrol, oil or similar liquid matter. Pay attention to the instructions of the manufacturers of the cleaning agents. The seals in the machine are not resistant to solvents.



The spray of solvents is inflammable, explosive and poisonous.

CAUTION !



When running your high pressure cleaner with hot water of 70° C (with B230 T 50°) raised temperatures occur.

Do not touch the machine without safety gloves.

Description

Water connection:

Please check that the high pressure cleaner has available the quantity of water specified on page 2 (techn. specs.) (Litres per minute).

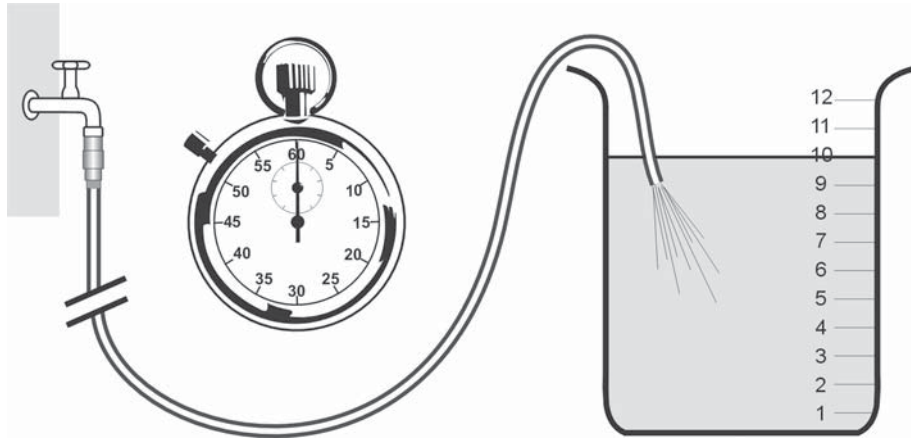

Test:

Allow the water supply hose to run for 1 minute into a bucket.

The received quantity of water must be at least the quantity given on page 2 !!!



Lack of water causes fast wear on seals (no warranty)

Brake

The high-pressure cleaner is fitted with a brake that prevents the machine from rolling away on uneven ground.

Always apply the brakes firmly when working with the machine !!!

Description



Brief operating instructions

1. Connect the high pressure hose with spray gun and machine.
2. Connect the suitable water supply.
3. Flush the air from the pump (open and close the spray gun several times).
4. Switch on the motor while the spray gun is open and commence cleaning.
5. After completing the work, completely empty the pump (switch the motor on for approximately 20 seconds without the suction

- Only use clean water ! Protect from frost !
- Do NOT !! tilt or turn round the high-pressure cleaner during transport

CAUTION !

Please pay attention to the regulations of your waterworks company.

In accordance with EN 61 770, the machine may not be directly connected to the public drinking water supply lines.

A brief connection however ist permissible according to DVGW (German Association for Gas and Water Affairs) if a tube ventilator with check valve (KRÄNZLE Order-No. 41.016 4) is built into the water supply.

Also indirect connection to the public drinking water supply lines is permissible by way of free emission in accordance with EN 61 770; e.g. by using a reservoir with a float valve.

Direct connection to a non-drinking water supply line is permissible.

High pressure hose and spray device

The high pressure hose and spray device supplied with the machine are made of high grade material, they are also optimized for the machine and marked as required by the appropriate regulations.

If replacement parts are required, only such parts that are authorized by the manufacturer and which bear the markings required by the appropriate regulations may be used. The high pressure hose and spray device must be connected in a pressure-tight manner. The high pressure hose may not be driven over, pulled excessively, or twisted. The hose may under no circumstances be pulled over sharp edges, since otherwise the guarantee is automatically void.



Safety notes

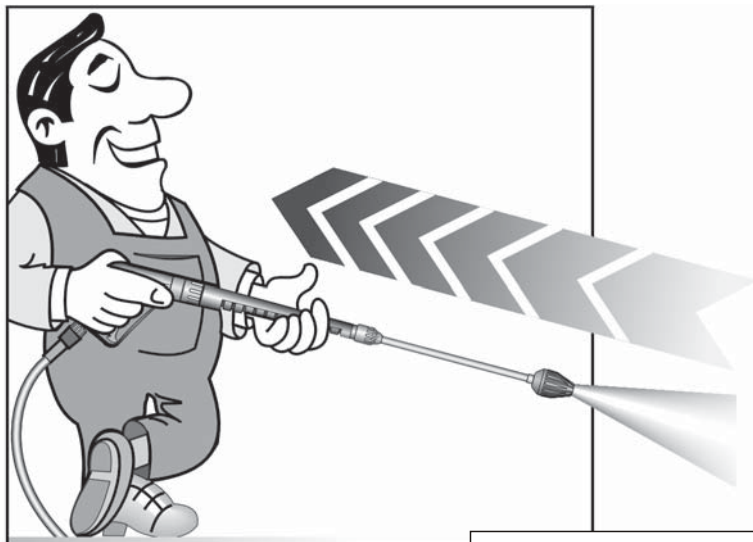

As to the recoil
- see notice on
page 2!

Apply the safety catch on the spray
gun after each use, in order to pre-
vent unintentional spraying!

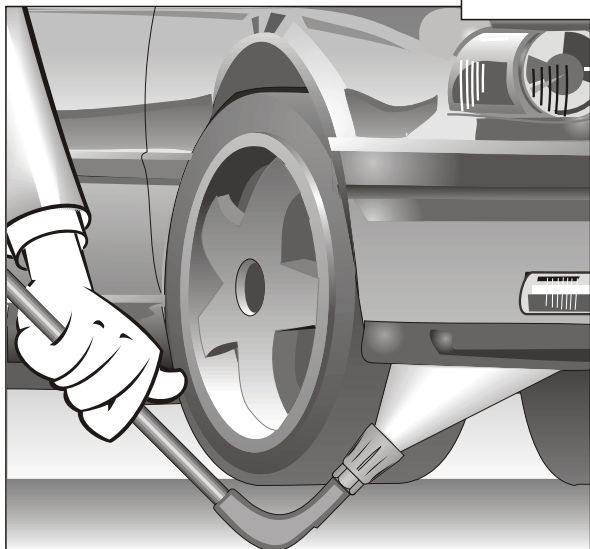
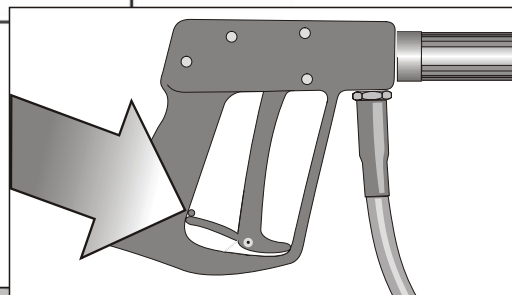

Always aim the underbody
lance. Note when using an
angled underbody lance,
like for example lance No.
41075, that there is a cer-
tain amount of torque in the
recoil.
(See also notice on page 2)

This is what you've purchased:

1. Spray gun with insulated
pistol grip and screw con-
nection

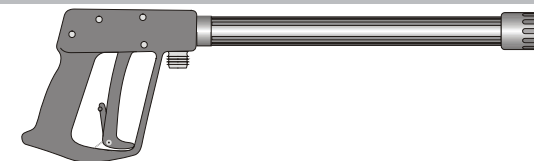

2. Spray lance with high pressure
nozzle, flat spray



3. Turbokiller



4. KRÄNZLE - high-pressure cleaners

B 170 T

B 200 T

B 240 T

B 270 T

B 230 T

incl. hose drum with 20 m HP-hose



5. Operation manual pump
Operation manual motor

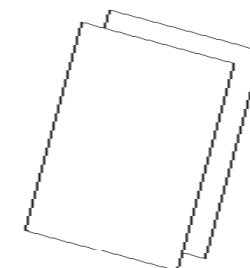

6. Water filter



Preparation for use

1. Check oil level (Pump and motor)



2. Connect high pressure Turbokiller to the spray

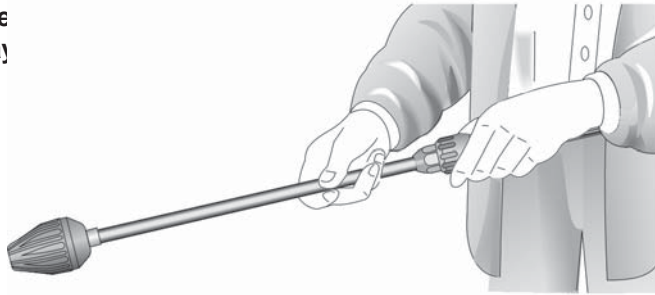

3. Unroll hose without kinks and connect with handgun and pump. Use HP hose of max. 20 m length.

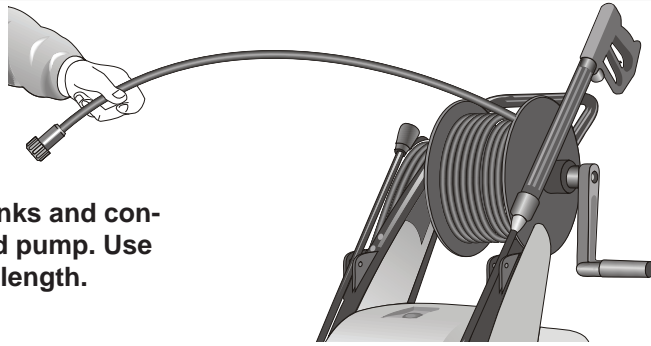

High pressure hose connected to machine and spray gun.

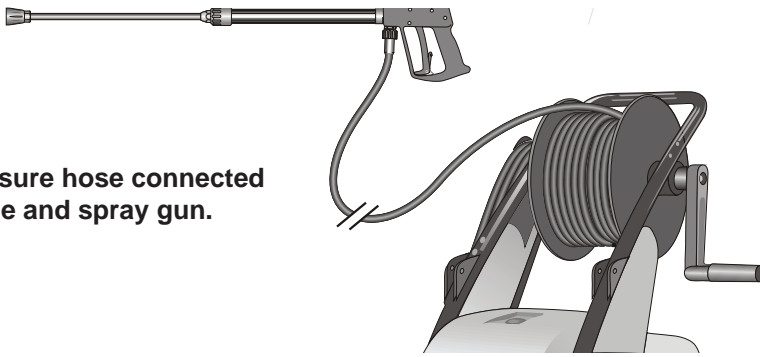

Preparation for use

4. The machine can be connected to a pressurised water line with cold or up to 70 °C hot water (see page 2). Ensure that the water supply ist clean when sucking from external sources. The hose cross section must be at least 1/2" = 12.7 mm (free passage). Filter must always be clean.



Please make sure that the filter is clean before using your high pressure cleaner.

Adjusting the pressure

This is accomplished by turning the handwheel. The default setting is maximum pressure.



5. Maximum induction height 2.5 m - see technical data on page 2.

Water

To shut down the pump:

1. Switch off the machine
2. Cut off the water supply
3. Open the spray gun briefly until the pressure is released
4. Apply the safety catch on the spray gun
5. Remove the water hose and high pressure hose
6. Drain the pump: switch on the motor for approx. 20 seconds
7. Winter: store the pump in rooms above 0° C
8. Clean the water filter

This is prohibited !

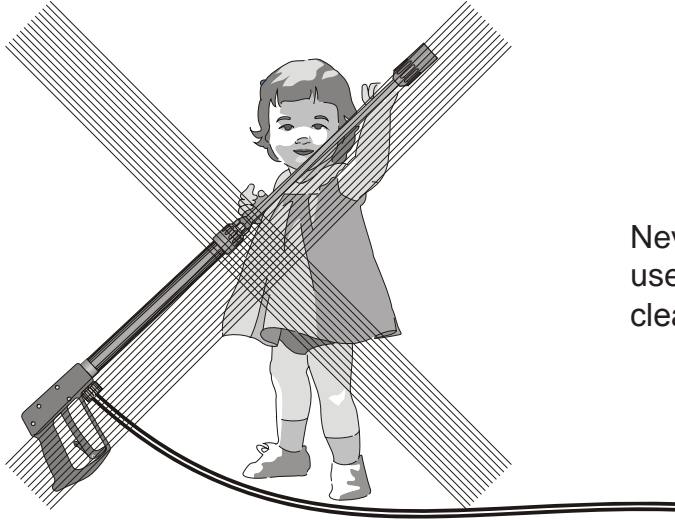

Never allow children to use the high pressure cleaner !

This is prohibited !

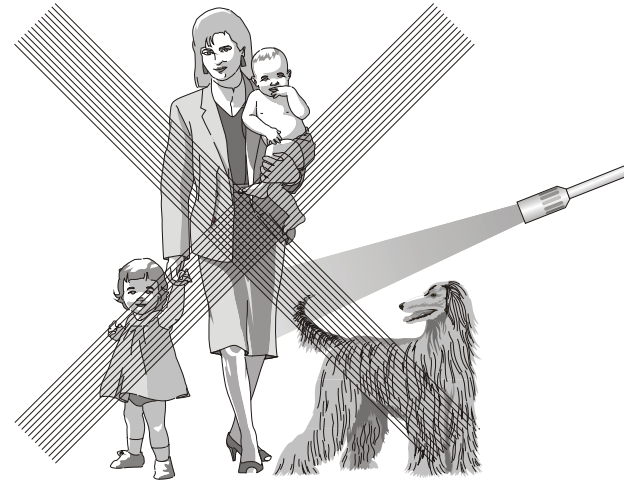

Never direct the water jet at people or animals !



Never direct the water jet at the machine itself !

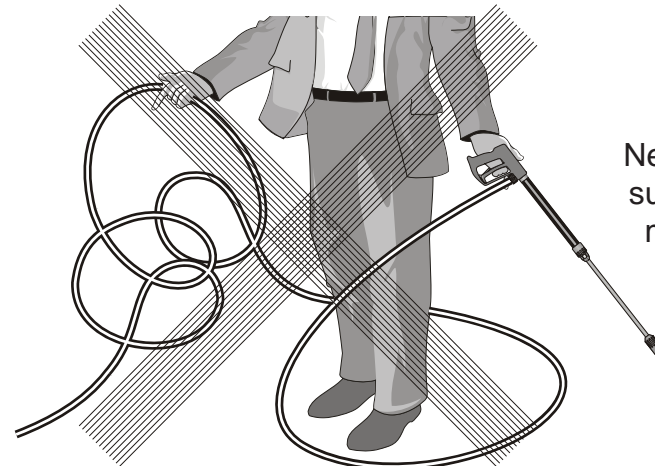

Never pull the high pressure hose if it has formed kinks or "nooses"! Never pull the hose over sharp edges !

Additional KRÄNZLE-accessories for ...

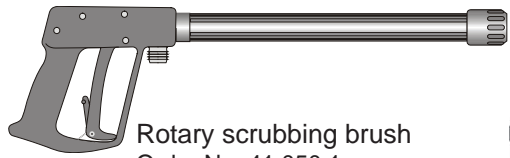

Rotary scrubbing brush
Order No. 41.050 1



Drain and pipe cleaning hose
8 m - Order No. 41.051
15 m - Order No. 41.058

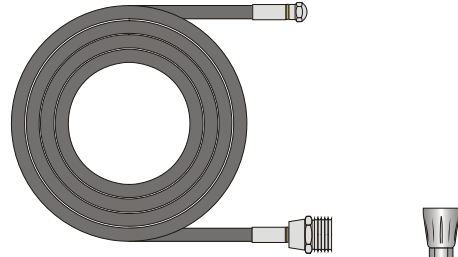

Underbody lance
Order No. 41.075

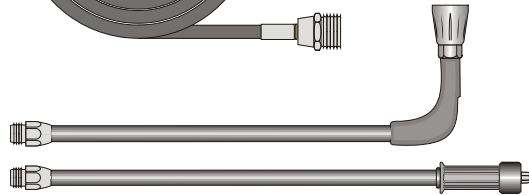

Sandblaster
Order No. 41.068 1

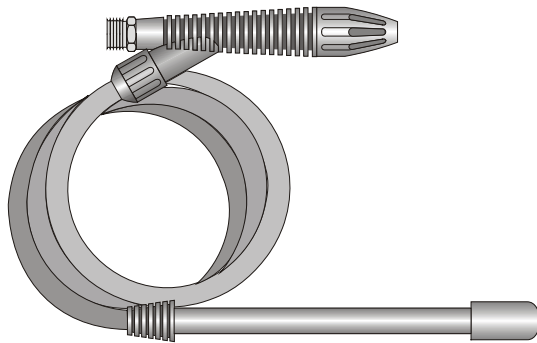

Flat brush
Order No. 41.073

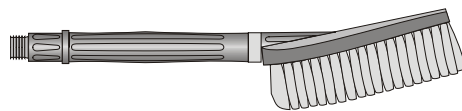

Environmental, refuse disposal and water protection regulations must be observed when using the accessories!

... further combination possibilities

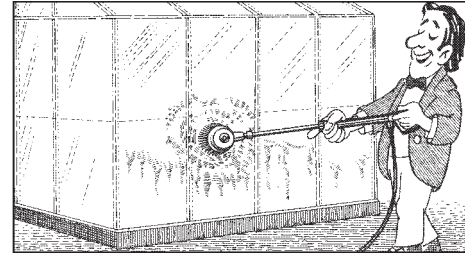

Car cleaning, glass, caravan, boat etc.
rotary washing brush with 40 cm extension and ST 30 nipple M 22 x 1,5

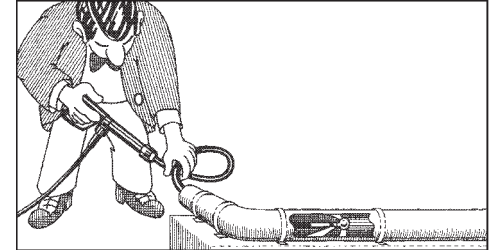

Cleaning pipes, channels and drains:
pipe cleaning hose with KN nozzle and ST 30 nipple M 22 x 1,5

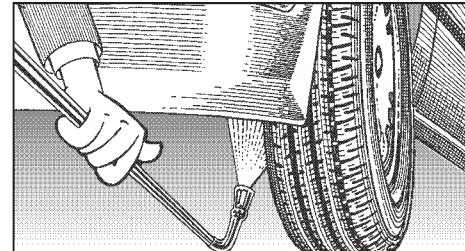

Underbody cleaning of cars, trailers and equipment: lance 90 cm with high pressure nozzle and ST 30 nipple M 22 x 1,5.
The lance must be aimed when spraying.

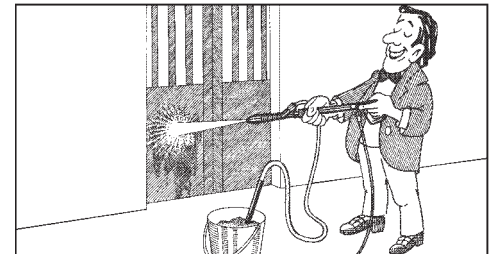

Blasting old paint, rust and facades: sandblasting injector with suction lance, 3 m PVC hose and ST 30 nipple.



When sandblasting you must wear protection clothes! Pay attention to the instructions of the manufacturer of the abrasive!

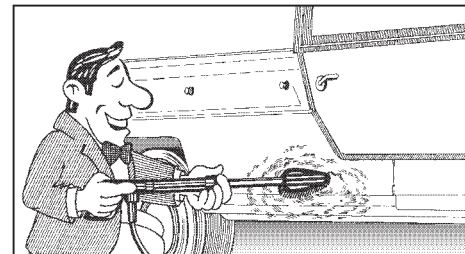

Cleaning cars and all smooth surfaces :
brush with ST 30 nipple M 22 x 1,5.

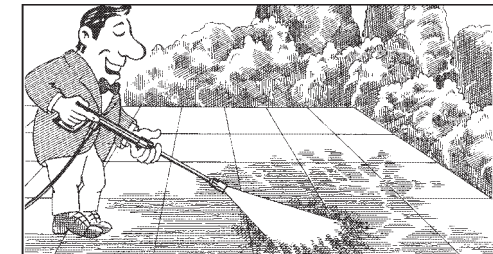

Rotary point sprayer for extreme soiling.
Dirtkiller with 40 cm extension and ST 30 nipple M 22 x 1,5.

Nozzle dirty or sticky!

- Pressure gauge does not show full pressure.
- Water comes out in spurts.
- If you do not use the high-pressure cleaner for some time the valves can stick

- The high-pressure hose vibrates.



The nozzle is blocked!

- No water but the gauge shows full pressure !

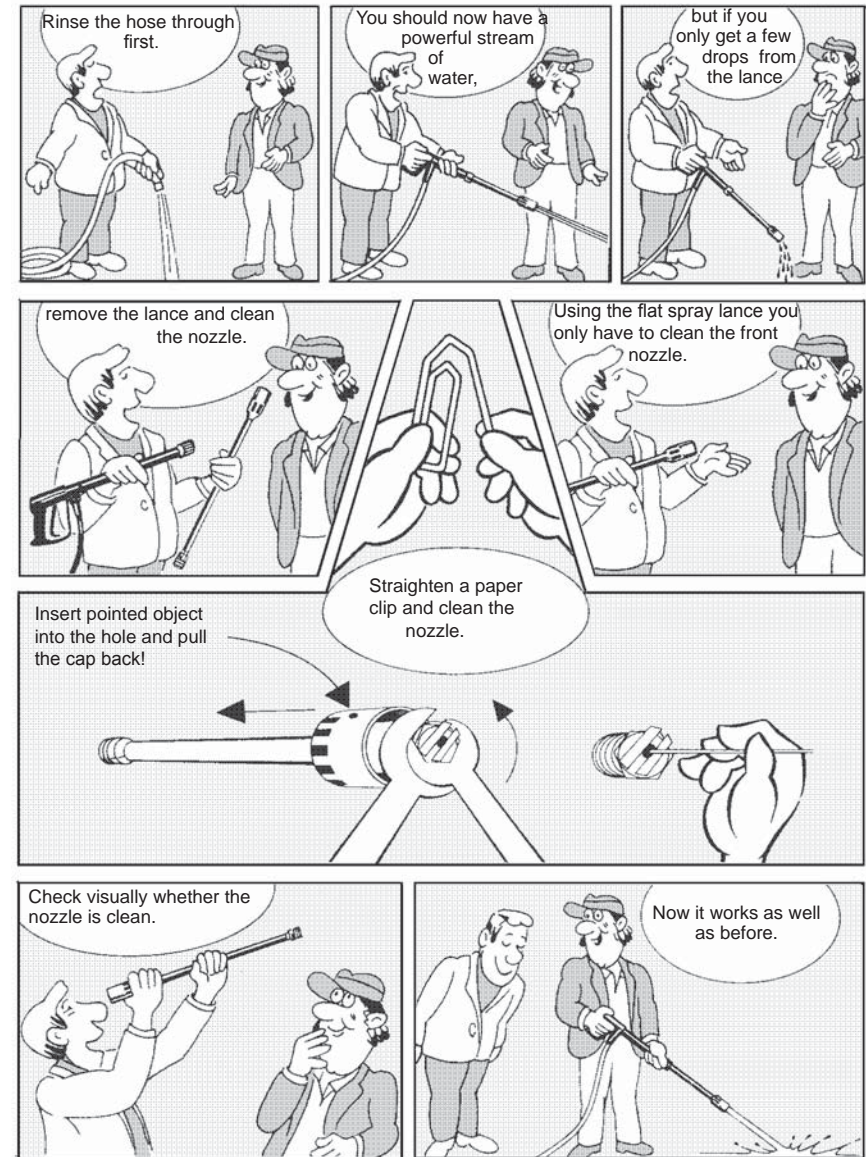

Stopping leaks from hose or gun

- After closing the gun the manometer shows full pressure !
- The pressure regulator switches on and off continuously!

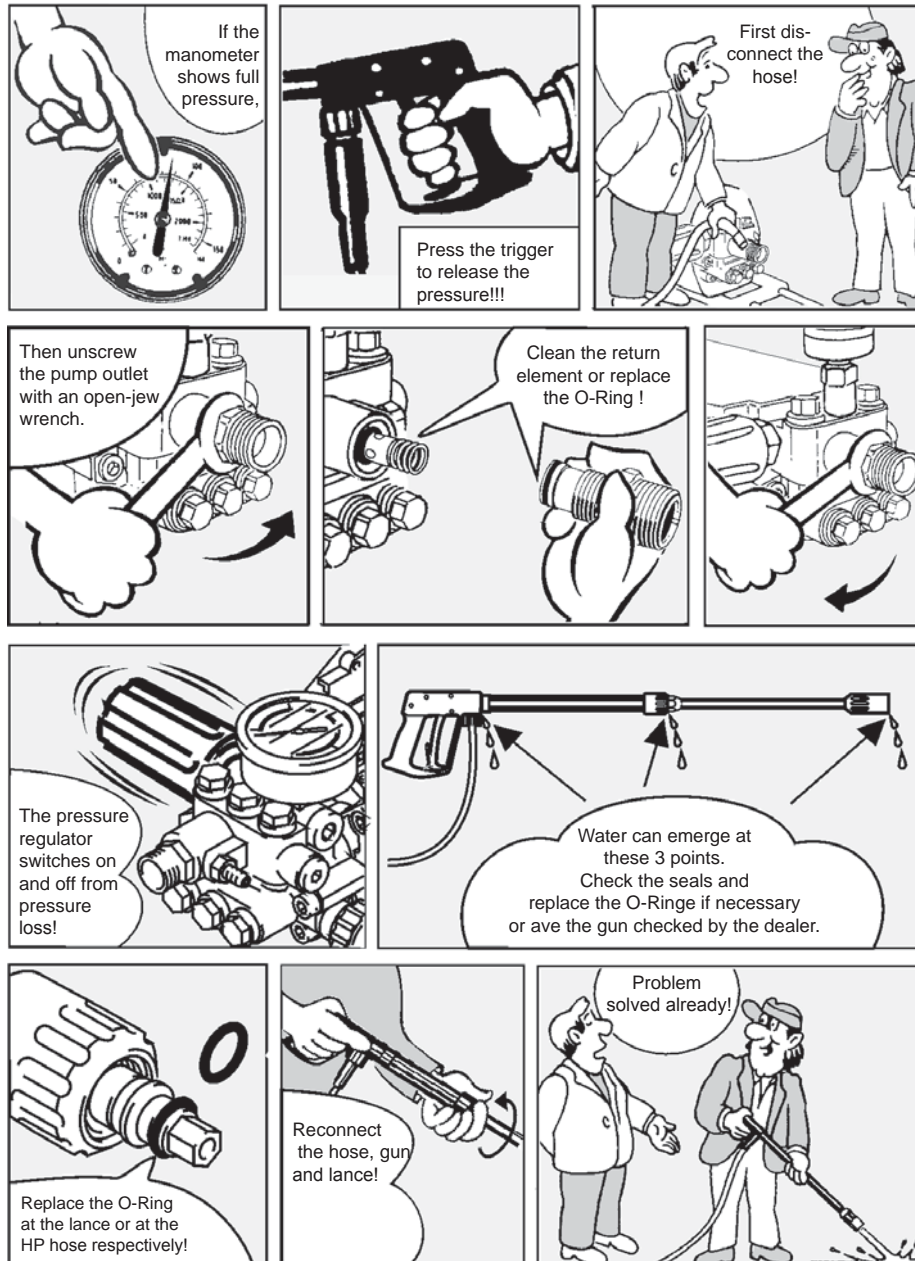

Inspections:

The machine must be inspected according to the „Guidelines for Liquid Spray Devices“ at least once every 12 months by a qualified person, to ensure that continued safe operation is guaranteed. The results of the inspection are to be recorded in writing. This may be done in any form.

Accident prevention

The machine is designed for accidents to be impossible if used correctly. The operator is to be notified of the risk of injury from hot machine parts and the high pressure water jet. The „Guidelines for Liquid Spray Devices“ must be complied with. (see page 12 and 13)

Check the oil level at the oil sight glass prior to each use.

(Ensure horizontal position!) The oil level should be at the middle of the sight glass. With high atmospheric humidity and temperature fluctuation there may be condensation (oil has a greyish colour); Then the oil must be changed.

Oil change for high-pressure pump B170 T / B200 T

First oil change after approx 50 hours of operation. Thereafter, no more oil change is required for the lifetime of the equipment. If it becomes necessary during repairs to perform an oil change, then the oil sight glass should be opened and the oil emptied into a container. The oil must be caught in a container and disposed of in a responsible, legal manner.

New oil: 0,3 l - Motor oil W 15/40

Oil change for high-pressure pump B230 T / B240 T / B270 T

The oil of your high pressure pump should be changed after approx. 40 hours of operation, or no later than when it takes an a grey or whitish colour. Open the oil-plug over a container and drain off all the oil. The oil must be caught in a contianer and disposed of in a responsible, legal manner.

New oil: 1,0 l - Castrol Formula RS

Oil leak

In the event of an oil leak contact customer service (dealer) immediately. (damage to environment or transmission)

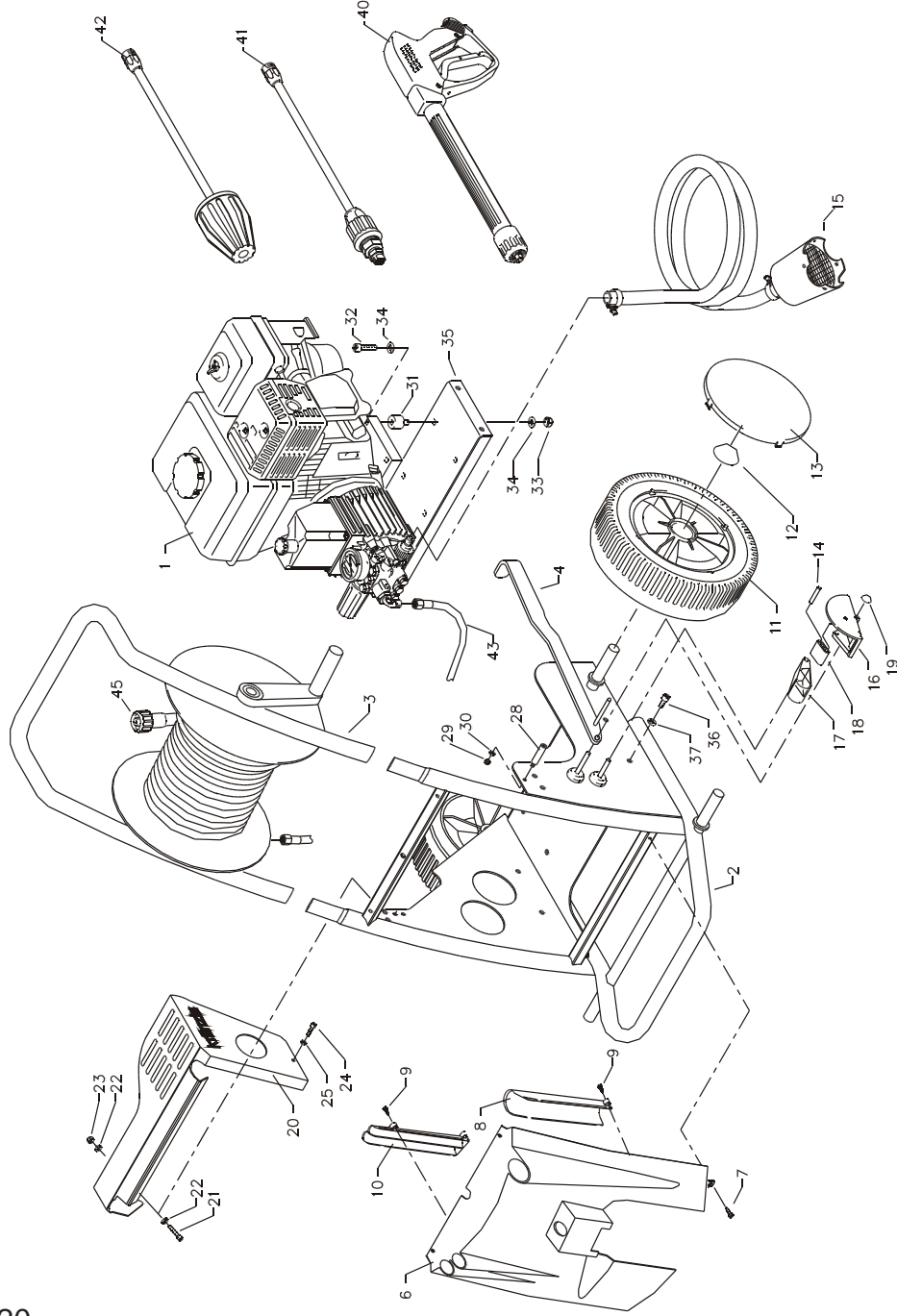

Spare parts list Kränzle B170 T / B200 T Complete assembly

No	Description	Qty.	Ord.-No	No	Description	Qty.	Ord.-No
1	Motor Honda GX 160 LX2 für B170 T	1	24 027	28	Distanzhülse	1	40 237
2	Motor Honda GX 200 LX2 für B200 T	1	24 027 2	29	Elastic - Stop Mutter M 6	1	14 152 1
3	Wagen	1	40 230	30	Scheibe 6,4	1	50 189
4	Schubbügel	1	40 245	31	Gummipuffer 40 x 30	4	40 220 1
6	Bremshebel	1	40 246	32	Schraube M 8 x 30	4	40 221
6	Frontplatte B170 T	1	40 231 1	33	Elastic - Stop Mutter M 8	4	41 410
6	Frontplatte B200 T	1	40 231 2	34	Scheibe 8,4 DIN 125	8	50 186
7	Blechschaube 4,8 x 12	4	44 112	35	Zwischenplatte	1	40 239
8	Köcher groß	1	40 232	36	Schraube M 8 DIN 933	4	40 140
9	Kunststoffschraube 5 x 14	7	43 426	37	Federring A8 DIN 127	4	44 222
10	Köcher klein	1	40 233	40	Midi-Pistole mit Verlängerung	1	12 160
11	Rad	4	44 017	41	Lanze mit Regeldüse 25045 für B170 T	1	41 053 2-05
12	Achsklemmring 20 mm	4	40 142	41	Lanze mit Regeldüse 25045 für B200 T	1	41 053 2-045
13	Radkappe	4	44 018		bitte Düsengröße mit angeben		
14	Stift 6 x 40	1	44 035 1	42	Turbokiller 05 bei B170 T	1	41 580-05
15	Saugschlauch 3 m mit Saugfilter	1	15 038 3	43	Turbokiller 045 bei B200 T	1	41 072 3
16	Bremspedal	1	44 022	44	Hochdruckschlauch 1m / DN 8	1	41 265
17	Bremsklotz	1	44 024	44	Hochdruckschlauch NW8 20m	1	41 083
18	Bremshebel	1	44 023	45	Schlauchtrommel kpl. mit 1m HD-Schlauch, jedoch ohne 20m HD-Schlauch	1	41 259 1
19	Starlockkappe 8 mm	1	44 165				
20	Abdeckung B170 T / B200 T	1	40 234				
21	Innensechskantschraube M 4 x 30	3	40 236				
22	Scheibe	6	43 472				
23	Elastic - Stop Mutter M 4	3	40 111				
24	Schraube M 6 x 12	1	43 421				
25	Federring A 6	1	44 222 1				

Spare parts list Kränzle B170 T / B200 T Transmission

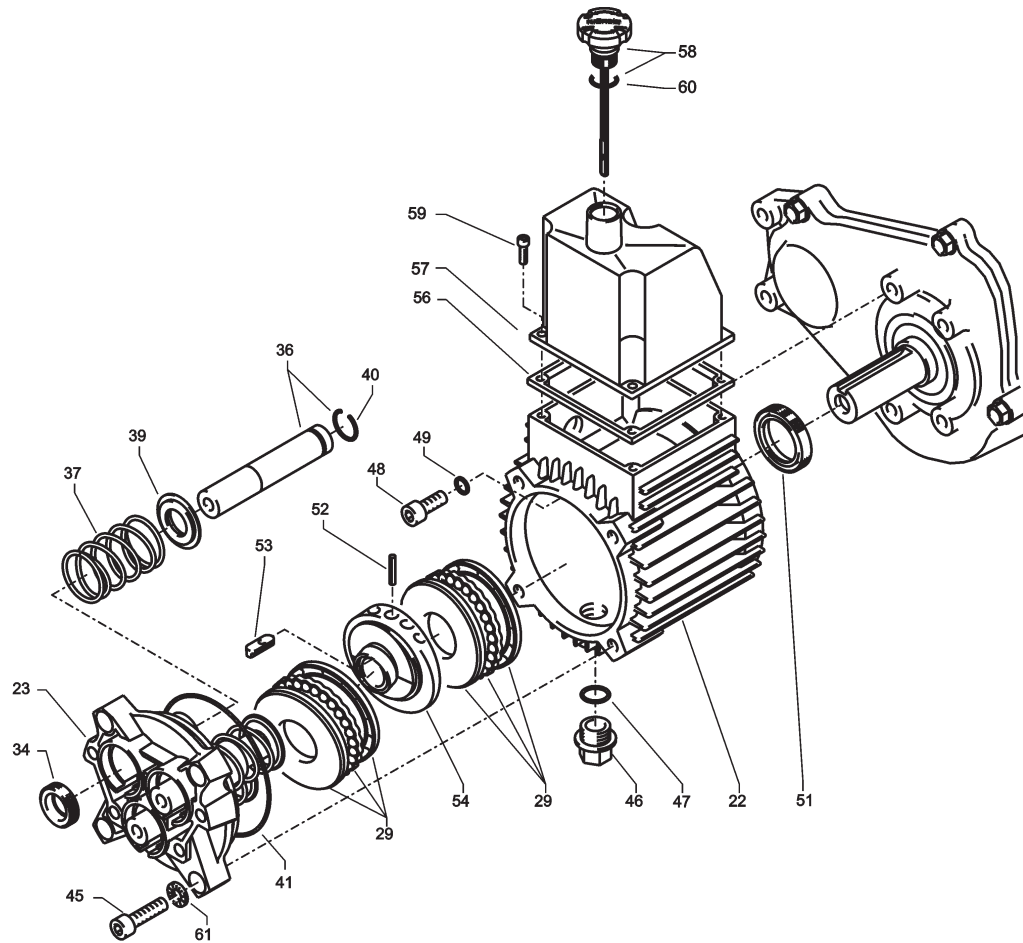

No	Description	Qty.	Ord.-No
22	Getriebegehäuse	1	41.481 1
23	Gehäuseplatte 18 mm	1	41.020 2
29	Axial-Rillenkugellager 3-teilig	2	43.486
34	Öldichtung 18 x 28 x 7	3	41.031
36	Plunger 18 mm	3	41.032 1
37	Plungerfeder	3	41.033
39	Federdruckscheibe 18 mm	3	41.034
40	Sprengring 18 mm	3	41.035
41	O-Ring Viton 88 x 2	1	41.021 1
45	Innensechskantschraube M 8 x 30	4	41.036 1
46	Ölablassstopfen M18x1,5 mit Magnet	1	48.020
47	O-Ring 12 x 2	1	15.005 1
48	Innensechskantschraube M 8 x 20	4	41.480
49	Kupferdichtring	4	41.500
51	Wellendichtring 25 x 35 x 5	1	41.019 5
52	Spannstift 3 x 16	1	14.148 1
53	Stufenkeil	1	41.183
54	Taumelscheibe 11,5°	1	41.028 6-11,5
56	Flachdichtung	1	41.019 3
57	Deckel	1	40.518
58	Ölmeßstab	1	42.520 1
59	Innensechskantschraube M 5 x 12	4	41.019 4
60	O-Ring 14 x 2	1	43.445

Spare parts list Kränzle B170 T / B200 T Valve housing APG for 18 mm plunger diameter

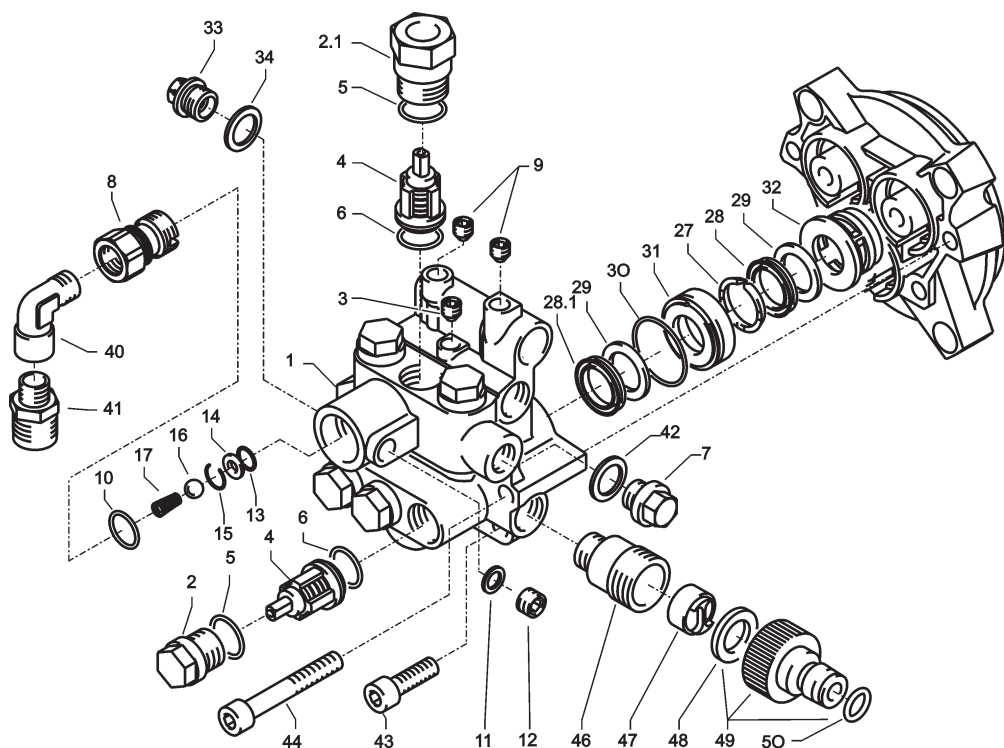

No	Description	Qty.	Ord.-No
1	Ventilgehäuse APG für 18 mm Plunger-Durchmesser	1	42.160 3
2	Ventilstopfen	5	41.714
2.1	Ventilstopfen mit R1/4" IG	1	42.026 1
3	Dichtstopfen M 10 x 1	1	43.043
4	Ventile (grün) für APG-Pumpe	6	41.715 1
5	O-Ring 16 x 2	8	13.150
6	O-Ring 15 x 2	6	41.716
7	Dichtstopfen R 1/4" mit Bund	1	42.103
8	Ausgangsteil R3/8" IG	1	40.248 1
9	Dichtstopfen M 8 x 1	2	13.158
10	O-Ring 18 x 2	1	43.446
11	Aluminium - Dichtring	3	13.275
12	Stopfen 1/4" AG mit ISK	1	13.387
13	O-Ring 11 x 1,5	1	12.256
14	Edelstahlsitz Ø 7	1	14.118
15	Sprengring	1	12.258
16	Edelstahlkugel Ø10	1	12.122
17	Rückschlagfeder „K“	1	14.120 1
27	Druckring	3	41.018
28	Manschette 18 x 26 x 4/2	3	41.013
28.1	Gewebemanschette 18 x 26 x 4/2	3	41.013 1
29	Backring	6	41.014
30	O-Ring 28,3 x 1,78	3	40.026
31	Leckagering	3	41.066
32	Zwischenring	3	41.015 2
33	Verschlussstopfen R3/8"	1	14.113
34	Kupferring 17 x 22 x 1,5	1	40.019
40	Einschraubwinkel R3/8" AG x R3/8" IG	1	40.256
41	ST30-Nippel R3/8" AG x M22 x 1,5	1	13.365 2
42	Usit-Ring	1	42.104
43	Innensechskantschraube M 8 x 30	2	41.036 1
44	Innensechskantschraube M 8 x 55	2	41.017 1
46	Sauganschluss	1	41.016
47	Wasserfilter	1	41.046 1
48	Gummidichtring	1	41.047 1
49	Steckkupplung	1	41.047 2
50	O-Ring	1	41.047 3
	Rep.-Satz Ventile für APG-Pumpe bestehend aus je 6x Pos. 4; 6x Pos. 5; 6x Pos. 6		41.748 1
	Rep.-Satz Manschetten 18 mm bestehend aus je 3x Pos. 27; 3x Pos. 28; 3x Pos. 28.1; 6x Pos. 29; 6x Pos. 30		41.049 2
	Ventilgehäuse kpl. mit Handrad		40.249

Unloader

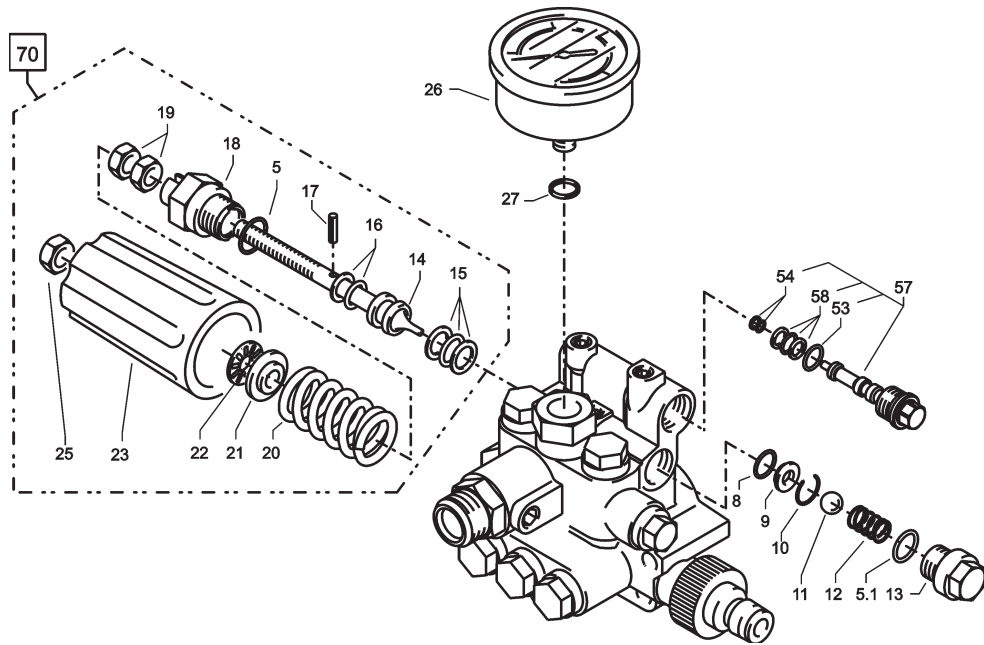

Kränzle B170 T / B200 T

Spare parts list Kränzle B170 T / B200 T
Unloader

No	Description	Qty.	Ord.-No
5	O-Ring 16 x 2	1	13.150
5.1	O-Ring 13,94 x 2,62	1	42.167
8	O-Ring 11 x 1,44	1	12.256
9	Edelstahlsitz	1	14.118
10	Sicherungsring	1	13.147
11	Edelstahlkugel	1	13.148
12	Edelstahlfeder	1	14.119
13	Verschlusschraube	1	14.113
14	Steuerkolben	1	14.134
15	Parbaks 16 mm	1	13.159
16	Parbaks 8 mm	1	14.123
17	Spannstift	1	14.148
18	Kolbenführung spezial	1	42.105
19	Kontermutter M 8 x 1	2	14.144
20	Ventilfeder schwarz	1	14.125
21	Federdruckscheibe	1	14.126
22	Nadellager	1	14.146
23	Handrad	1	14.147
25	Elastic-Stop-Mutter M 8 x 1	1	14.152
26	Manometer 0-250 Bar	1	15.039
27	Aluminium-Dichtring	4	13.275
50	O-Ring 3,3 x 2,4	1	12.136
53	O-Ring 14 x 2	1	43.445
54	Parbaks 4mm	1	12.136 2
57	Blindverschluss mit Dichtungen	1	44.551
58	Parbaks 7mm	1	15.013
70	Steuerkolben kpl. mit Handrad		43.444

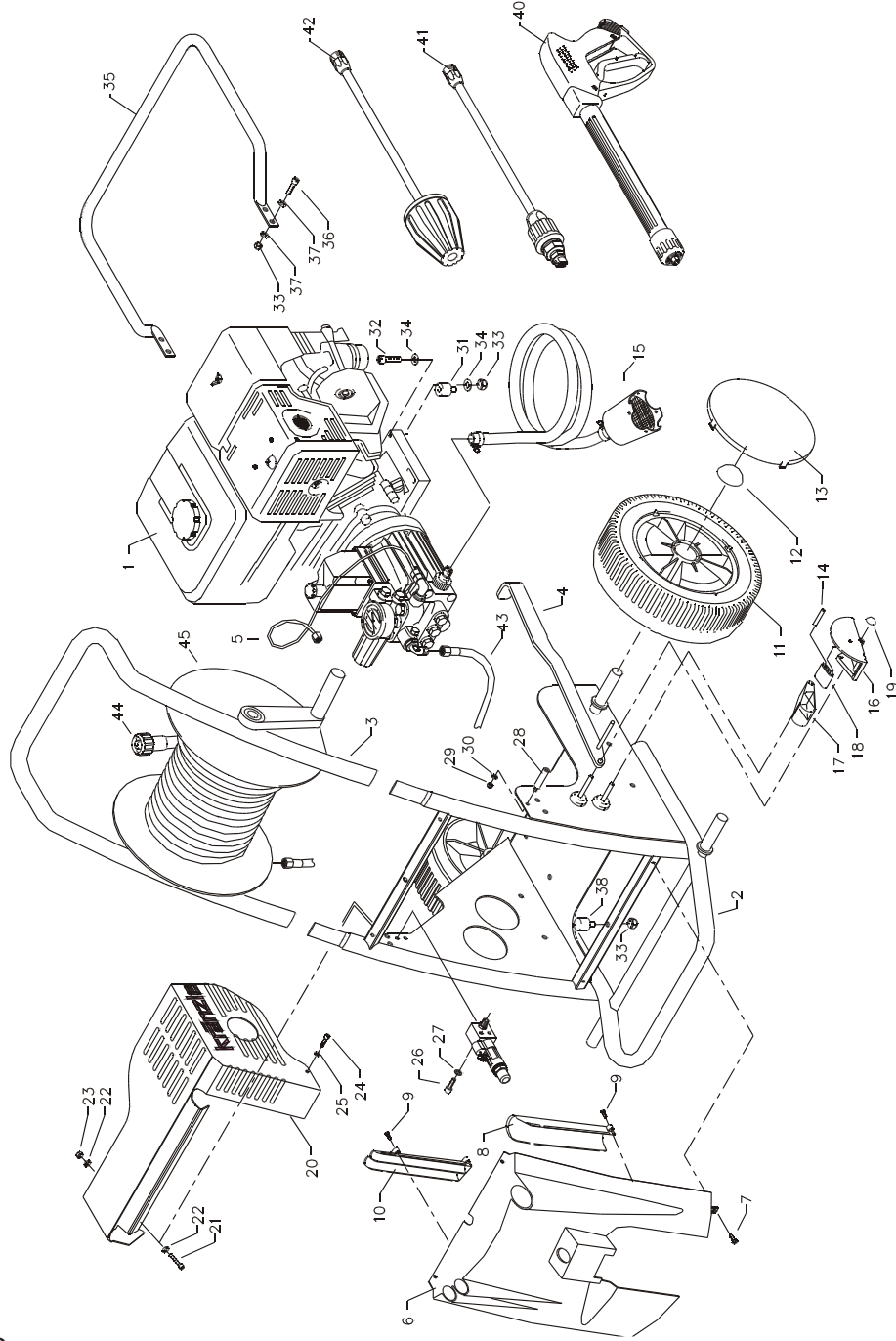

Spare parts list Kränzle B230 T - B240 T - B270 T Complete assembly

No	Description	Qty.	Ord.-No	No	Description	Qty.	Ord.-No
1	Motor Honda GX 340 LX2 für B240 T	1	24.026	26	Sechskantschraube M6 x 16	2	50.173
2	Motor Honda GX 390 LX2 für B230/270 T	1	24.026.1	27	Scheibe 6,4	2	50.189
3	Wagen	1	40.230	28	Distanzhülse	1	40.237.1
4	Schubbügel	1	40.245	29	Elastic - Stop Mutter M 6	1	14.152.1
5	Bremshebel	1	40.246	30	Scheibe 6,4	1	50.189
6	Druckmeßleitung für Drehzahlregulierung	1	44.102	31	Gummipuffer 40 x 30	4	40.220.1
7	Frontplatte B230 T	1	40.231.3	32	Schraube M 8 x 30	4	41.221
8	Frontplatte B240 T	1	40.231.4	33	Elastic - Stop Mutter M 8	8	41.410
9	Frontplatte B270 T	1	40.231.5	34	Scheibe 8,4	8	40.515
10	Blechschrabe 4,8 x 12	4	44.112	35	Schutzbügel	1	40.247
11	Köcher groß	1	40.232	36	Sechskantschraube M 8 x 25	4	44.137
12	Kunststoffschrabe 5 x 14	7	43.426	37	Unterlegscheibe DIN125 8,4	8	50.186
13	Köcher klein	1	40.233	38	Gummipuffer 30 x 20	1	42.516
14	Rad	4	44.017	40	Pistole mit Verlängerung - Startlett II	1	41.053.1
15	Achsklemmring 20 mm	4	44.017	41	Lanze mit Regeldüse 2505 bei B240 T	1	41.053.2-05
16	Radkappe	4	44.018		Lanze mit Regeldüse 25045 bei B270 T	1	41.053.2-045
17	Stift 6 x 40	1	44.035.1		Lanze mit Regeldüse 2507 bei B230 T	1	41.053.2-07
18	Saugschlauch 3 m mit Saugfilter	1	15.038		bitte Düsengröße mit angeben		
19	Bremspedal	1	44.024	42	Turbokiller 05 bei B240 T	1	41.580-05
20	Bremsklotz	1	44.165		Turbokiller 045 bei B270 T	1	41.072.3
21	Bremshebel	1	44.024	43	Turbokiller 07 bei B230 T	1	41.072.7
22	Starlockkappe 8 mm	1	44.165		Hochdruckschlauch 1m / DN 8	1	41.265
23	Abdeckung B230/240/270 T	1	40.235	44	Hochdruckschlauch NW8 20m	1	41.083
24	Innensechskantschraube M 4 x 30	3	40.236	45	Schlauchtrommel kpl. mit 1m HD-Schlauch, jedoch ohne 20m HD-Schlauch	1	41.259.1
25	Scheibe	6	43.472				
26	Elastic - Stop Mutter M 4	3	40.111				
27	Schraube M 6 x 12	1	43.421				
28	Federring A 6	1	44.222.1				

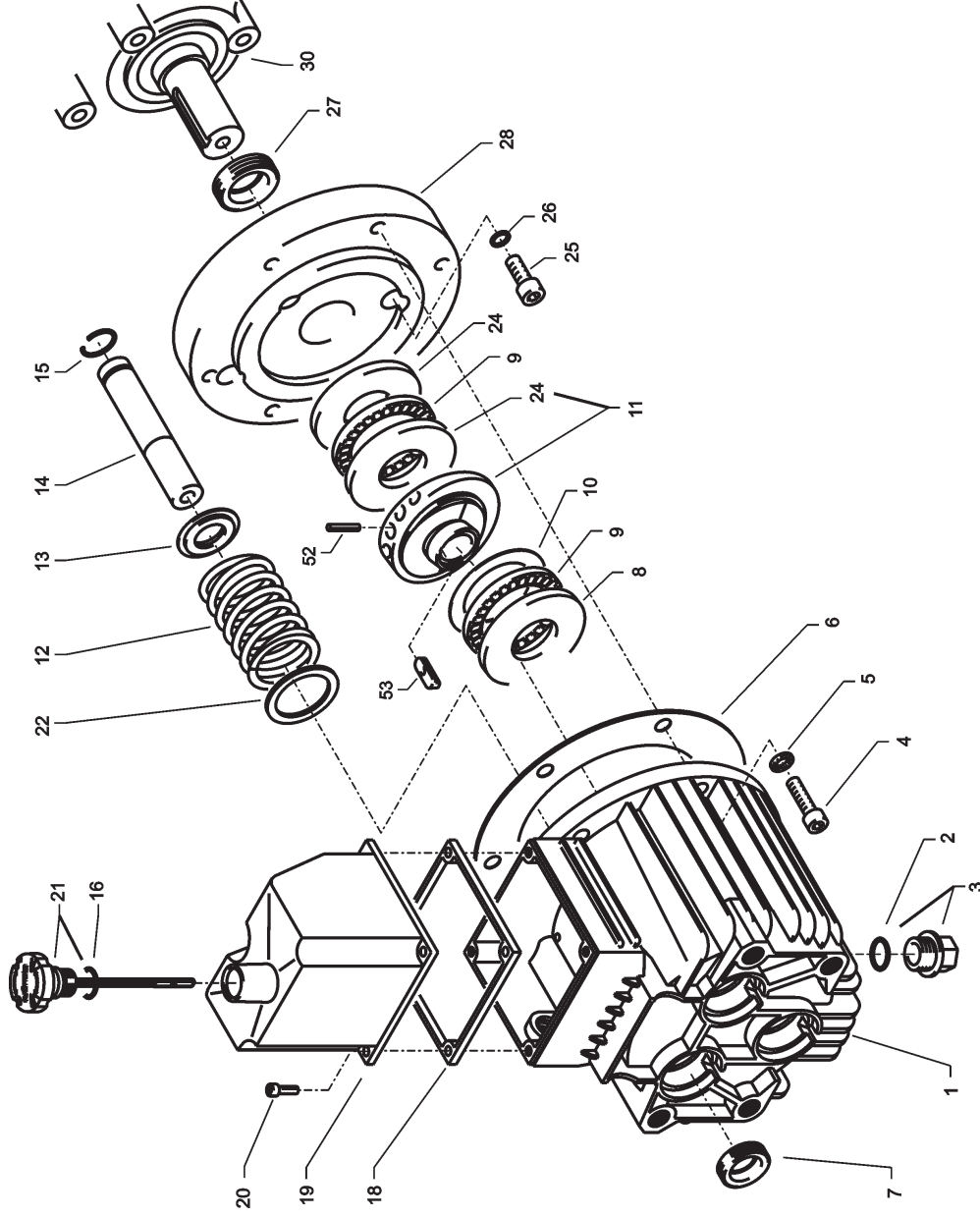

Spare parts list KRÄNZLE B230 T - B240 T - B270 T
Transmission unit AQ-Pump

No	Description	Qty.	Ord.-No
1	Ölgehäuse	1	40.501
2	Cu-Dichtring	1	40.052
3	Ölablassstopfen R 3/8"	1	42.019
4	Innensechskantschraube M 8 x 25	6	40.053
5	Sicherungsscheibe	6	40.054
6	Flachdichtung	1	40.511
7	Öldichtung 20 x 30 x 7	3	40.044 1
8	Wellenscheibe	1	40.043
9	Axial-Rollenkäfig	1	40.040
10	AS-Scheibe	1	40.041
11	Taumscheibe 10,2° bei B230 T Taumscheibe 8,0° bei B240 T Taumscheibe 8,0° bei B270 T	1 1 1	40.055-10,2 40.055-8,0 40.055-8,0
12	Plungerfeder	3	40.506
13	Federdruckscheibe	3	40.510
14	Plunger 20 mm (lang)	3	40.505
15	Sprengring	3	40.048
16	O-Ring 14 x 2	1	43.445
18	Flachdichtung	1	41.019 3
19	Deckel Ölgehäuse	1	40.518
20	Innensechskantschraube M 5 x 12	4	41.019 4
21	Ölmesstab	1	42.520 2
22	Stützscheibe	3	40.513
24	Gehäusescheibe	2	40.039
25	Innensechskantschraube M 8 x 30	4	41.036 1
26	Kupfer-Dichtring	4	41.500
27	Dichtring 30 x 42 x 7	1	40.224
28	Flansch für B 16/220	1	40.223
30	Motor Honda GX 340 LX2	1	24.026
30.1	Motor Honda GX 390 LX2	1	24.026 1
52	Spannstift 3 x 16	1	14.148 1
53	Stufenkeil	1	40.222

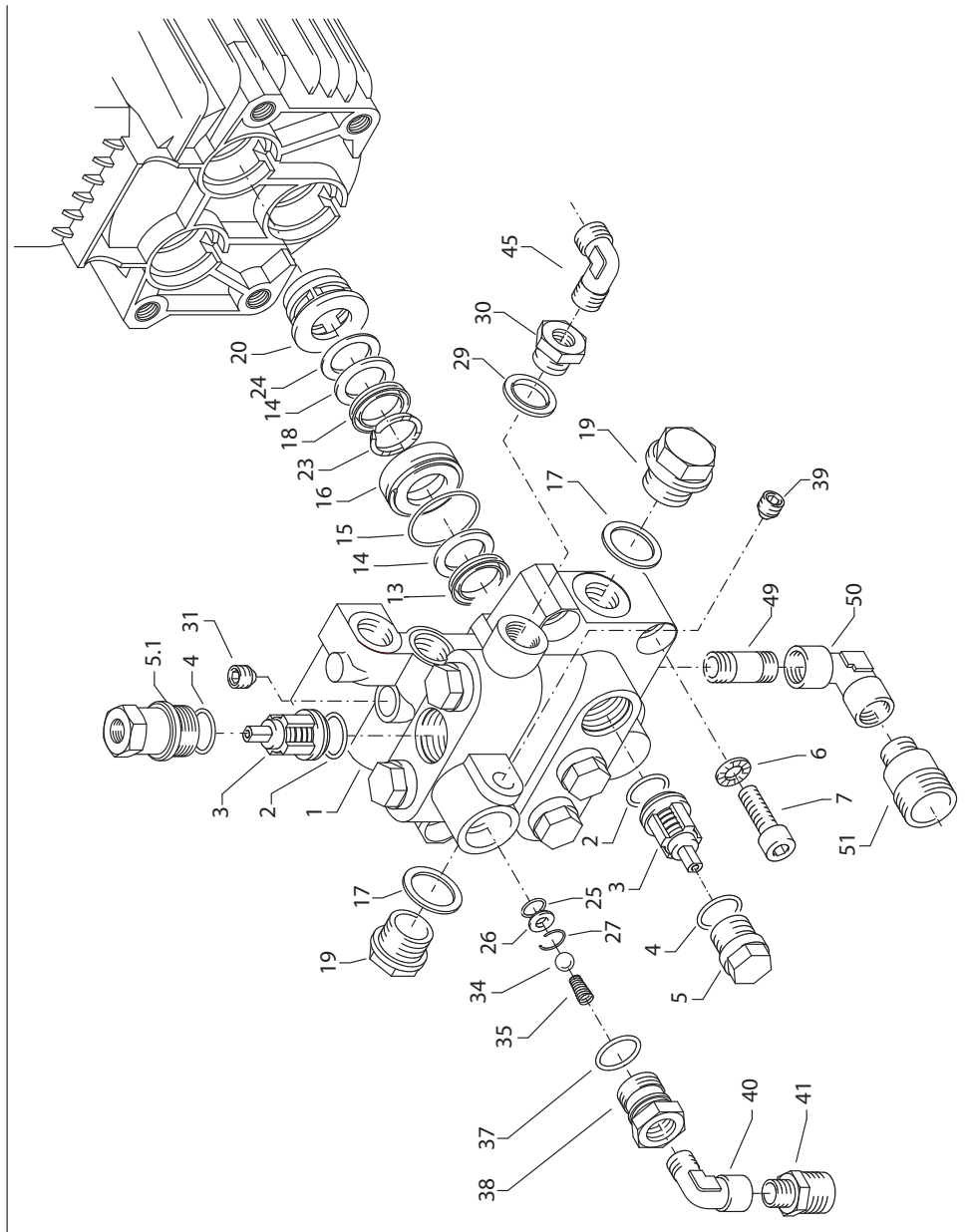

Spare parts list Kränzle B230T - B240T - B270T
Valve housing for integrated AQ-Pump

No	Description	Qty.	Ord.-No	No	Description	Qty.	Ord.-No
1	Ventilgehäuse AQ mit integr. UL ohne integr. Druckschalter	1	40.521 2	29	Dichtring 17 x 22 x 1,5 (Kupfer)	1	40.019
2	O-Ring 18 x 2	6	40.016	30	Stopfen 3/8" mit 1/8" IG	1	40.242
3	Einlass- / Auslass- Ventil	6	42.024	31	Dichtstopfen M 10 x 1	1	43.043
4	O-Ring 21 x 2	6	42.025	34	Edelstahlkugel Ø10	1	12.122
5	Ventilstopfen	5	42.026	35	Rückschlagfeder „K“	1	14.120 1
5.1	Ventilstopfen mit R 1/4" IG	1	42.026 2	37	O-Ring 18 x 2	1	43.446
6	Sicherungsring	4	40.032	38	Ausgangsstück R3/8" IG	1	40.248 1
7	Innensechskantschraube M 12 x 45	4	40.504	39	Dichtstopfen	1	13.385
13	Gewebemanschette	3	40.023	40	Einschraubwinkel R3/8" AG x R3/8" IG	1	40.256
14	Backring 20 mm	6	40.025	41	ST30-Nippel R3/8" AG x M22 x 1,5	1	13.365 2
15	O-Ring 31,42 x 2,62	3	40.508	45	Winkelverschraubung R 1/8" x 6	1	44.110 1
16	Leckagering 20 x 36 x 13,3	3	40.509	49	Distanzrohr 48 mm bds. R3/8" AG	1	41.628
17	Cu-Dichtring 21 x 28 x 1,5	2	42.039	50	Winkel R3/8" IG / IG	1	44.138
18	Gummimanschette	3	40.512	51	Sauganschluss R 3/8" AG x R3/4"	1	41.016 0
19	Verschlusschraube R 1/2"	2	42.032				
20	Distanzring mit Abstützung	3	40.507				
23	Druckring 20 mm	3	40.021				
24	Zwischenring 20 mm	3	40.516				
25	O-Ring 11 x 1,5	1	12.256				
26	Edelstahlstift Ø 7	1	14.118				
27	Sprengring	1	13.147				
	Repair kits:						
	Rep.-kit sleeves						40.065 1
	Consisting of: 3x No. 13; 6x No. 14;						
	3x No. 15; 3x No. 16; 3x No. 18;						
	3x No. 20; 3x No. 23						
	Repair kit sleeves w/o brass parts						40.517
	Consisting of:						
	3x No. 13; 6x No. 14; 3x No. 15;						
	3x No. 18; 3x No. 23						
	Repair kit valves						40.062 1
	Consisting of:						
	6x No. 2; 6x No. 3; 6x No. 4						

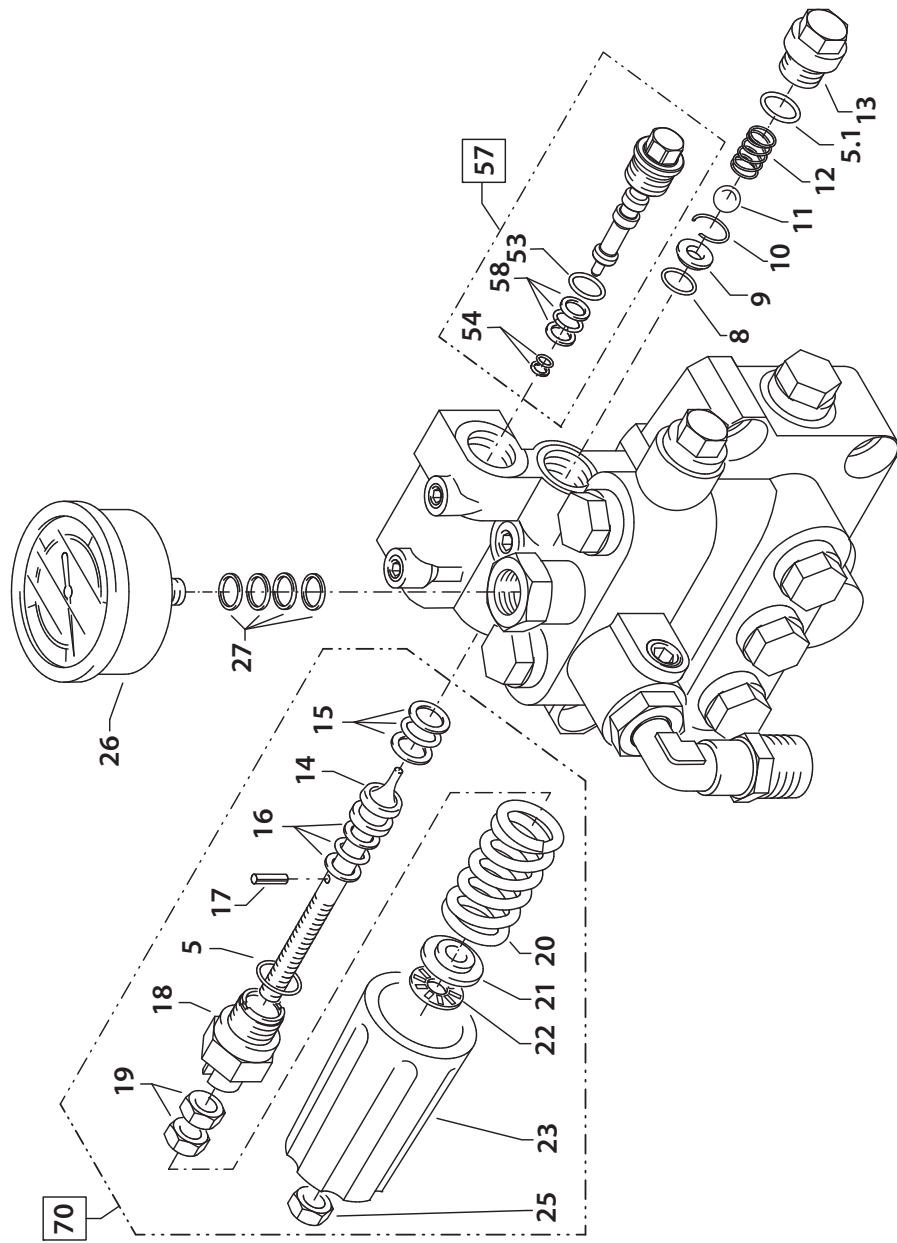

Spare parts list Kränzle B230T - B240T - B270T
Unloader valve AQ-Pump

No	Description	Qty.	Ord.-No
5	O-Ring 16 x 2	1	13.150
5.1	O-Ring 13,94 x 2,62	1	42.167
8	O-Ring 11 x 1,44	1	12.256
9	Edelstahlsitz	1	14.118
10	Sicherungsring	1	13.147
11	Edelstahlkugel	1	13.148
12	Edelstahlfeder	1	14.119
13	Verschlusssschraube	1	14.113
14	Steuerkolben	1	14.134
15	Parbaks 16 mm	1	13.159
16	Parbaks 8 mm	1	14.123
17	Spannstift	1	14.148
18	Kolbenführung spezial	1	42.105
19	Kontermutter M 8 x 1	2	14.144
20	Ventilfeder schwarz	1	14.125
21	Federdruckscheibe	1	14.126
22	Nadellager	1	14.146
23	Handrad	1	14.147
25	Elastic-Stop-Mutter M 8 x 1	1	14.152
26	Manometer 0-400 Bar	1	15.039.4
27	Aluminium-Dichtring	4	13.275
53	O-Ring 14 x 2	1	43.445
54	Parbaks 4 mm	1	12.136.2
57	Blindverschluss mit Dichtungen	1	44.551
58	Parbaks 7 mm	1	15.013
70	Steuerkolben kpl. mit Handrad		43.444

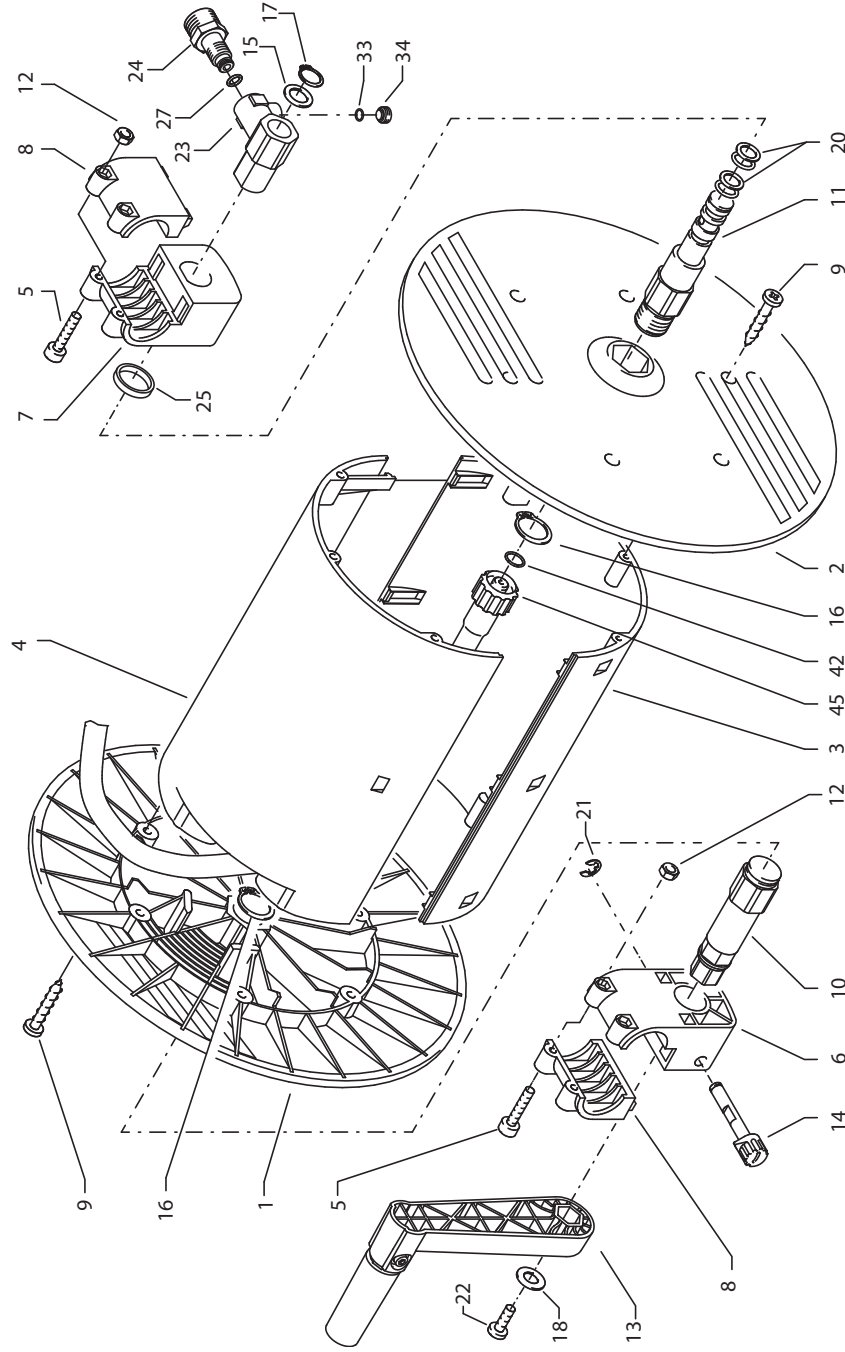

Spare parts list B 170 - 270 T
Hose drum

No	Description	Qty.	Ord.-No	No	Description	Qty.	Ord.-No
1	Seitenschale Schlauchführung	1	40.302	21	Sicherungsscheibe 6 DIN6799	1	40.315
2	Seitenschale Wasserführung	1	40.301	22	Schraube M 5 x 10	1	43.021
3	Trommel Unterteil	1	40.304	23	Drehgelenk	1	40.167
4	Trommel Oberteil	1	40.303	24	Anschlusssteil	1	40.308 1
5	Innensechskantschraube M 4 x 30	4	40.236	25	Distanzring	1	40.316
6	Lagerklotz mit Bremse	1	40.306	27	O-Ring 6,68 x 1,78	1	40.585
7	Lagerklotz links	1	40.305	33	O-Ring 6 x 1,5	1	13.386
8	Klemmstück	2	40.307	34	Stopfen M 10 x 1	1	13.385
9	Kunststoffschraube 5,0 x 20	12	50.157	42	O-Ring 9,3 x 2,4	4	13.273
10	Antriebswelle	1	40.310	45	Hochdruckschlauch 20 m NW 8	1	41.083
11	Welle Wasserführung	1	40.311		Schlauchtrommel kpl.		41.259 0
12	Elastic-Stop-Mutter M 4	4	40.111		ohne Schlauch		
13	Handkurbel klappbar	1	40.320 0		Schlauchtrommel kpl.		41.259 1
14	Verriegelungsbolzen	1	40.312		mit Schlauch		
15	Scheibe MS 16 x 24 x 2	1	40.181				
16	Wellensicherungsring 22 mm	2	40.117				
17	Wellensicherungsring 16 mm	1	40.182				
18	Unterlegscheibe Ø 6,4	1	50.189				
20	Parbaks 16 mm	2	13.159				

Speed control

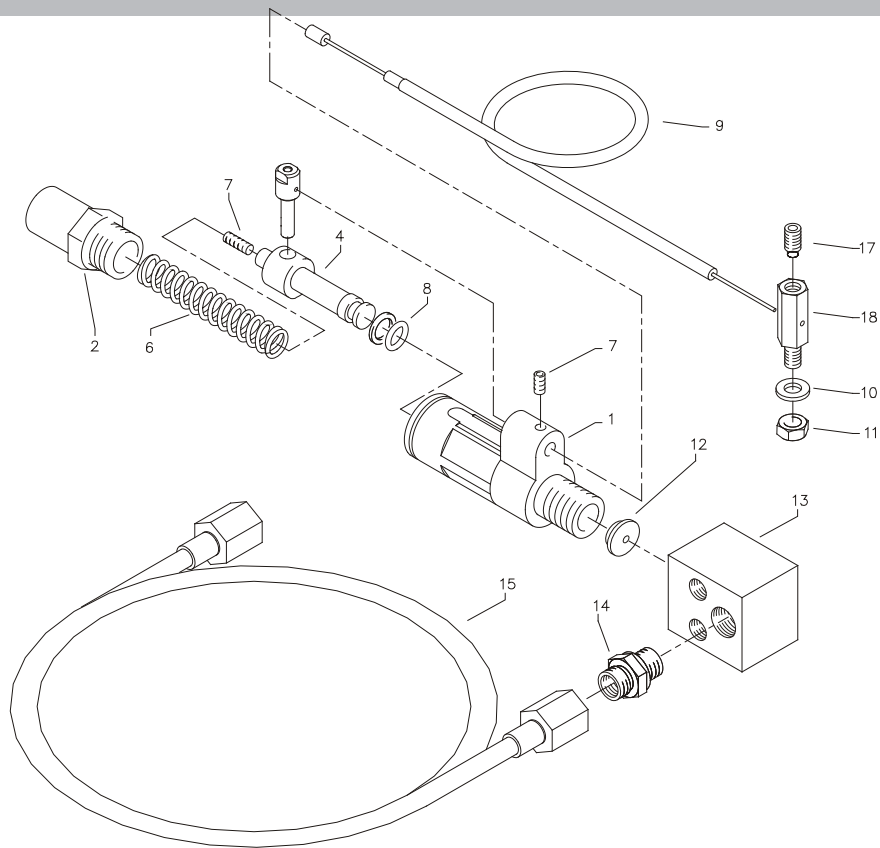

Spare parts list Kränzle B230 T / B240 T / B270 T
Speed control

No	Description	Qty.	Ord.-No
1	Grundteil	1	42.581
2	Druckhülse	1	42.584
4	Steuerkolben	1	42.582
5	Querbolzen	1	42.583
6	Druckfeder 2,0 x 9,5 x 70	1	42.587
7	Gewindestift M4 x 6 DIN 913	1	43.469
8	Parbaks 7 mm	1	15.013
9	Bowdenzug	1	40.244
10	Unterlegscheibe 6,4 DIN 125	1	50.189
11	Sechskantmutter M6	1	14.152 1
12	Drosselscheibe	1	42.589
13	Anschlussblock	1	40 241
14	Verschraubung 1/8"x 6l	1	40 591 1
15	Druckmessleitung	1	42.593
17	Gewindestift M 6 x 12 DIN915	1	42.590
18	Klemmbolzen	1	42.591

Standard regulation nozzle

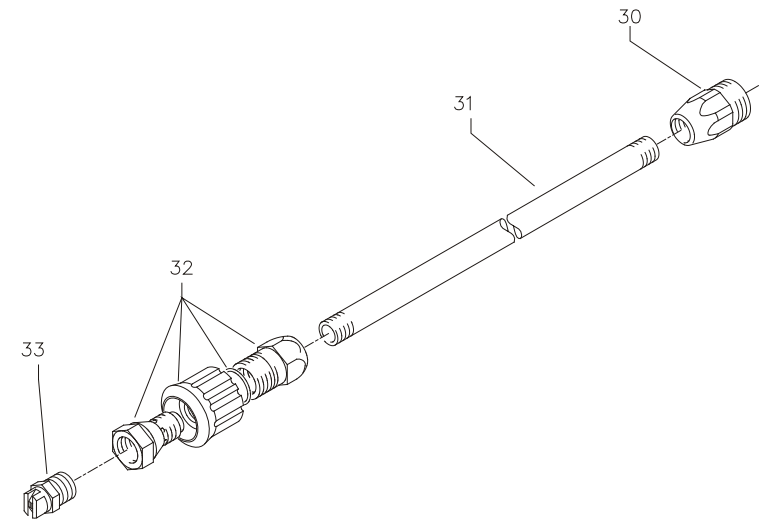

Pos.	Bezeichnung	Stck	Best.Nr.
30	Nippel ST30 M22x1,5 AG / M 12 x 1	1	13.363
31	Rohr 400 mm, bds. M 12 x 1	1	15.002
32	Regeldüse mit Regulierring	1	13.201 2
33	Flachstrahldüse 25045 bei B200		D 25 045
	Flachstrahldüse 2505 bei B170/240 T/270 T		D 25 05
	Flachstrahldüse 2507 bei B230 T		D 25 07
	bitte Düsengröße mit angeben		

Starlet II

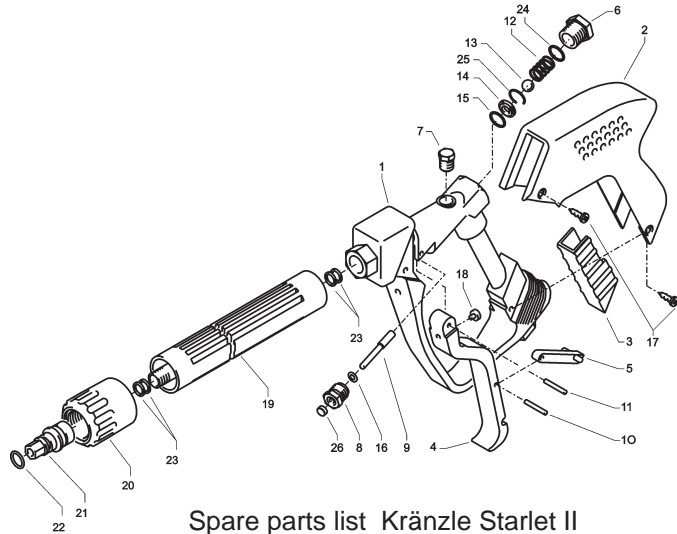

Spare parts list Kränzle Starlet II

No	Description	Qty.	Ord.-No
1	Ventilkörper mit Handgriff	1	12.294
2	Schutzhülse	1	12.295
3	Abdeckschutz	1	12.296
4	Abzugshebel grau	1	12.298 3
5	Sicherungshebel	1	12.149
6	Abschlusschraube M 16 x 1	1	12.247
7	Stopfen	1	12.287
8	Gewindeführungshülse 3mm R1/4" AG	1	12.250 1
9	Aufsteuerbolzen abgesetzt 3mm	1	12.284 1
10	Stift	1	12.148
11	Lagernadel	1	12.253
12	Edelstahlfeder	1	12.246
13	Edelstahlkugel	1	12.245
14	Edelstahlsitz	1	14.118
15	O-Ring 11 x 1,44	1	12.256
16	O-Ring 2,84 x 2,62	1	12.136 1
17	Blechschaube 3,9 x 8,5	4	41.079
18	Druckstück	1	12.252
19	Rohr kunststoffumspritzt bds. R 1/4" AG	1	15.004 5
20	Überwurfmutter ST30 M 22 x 1,5 IG	1	13.276 1
21	Außen-Sechskant-Nippel R 1/4" IG	1	13.277 1
22	O-Ring 9,3 x 2,4	1	13.273
23	Aluminium-Dichtring	4	13.275
24	O-Ring 15 x 1,5	1	12.129 1
25	Sicherungsring	1	12.258
26	Gleitbüchse 3mm	1	12.289 1
	Starlet-Gun with extention		12.320 2

Repair kit „Starlet II“
consisting of 1x No.: 9,10,13,14,15 12.299

M2000 - Gun

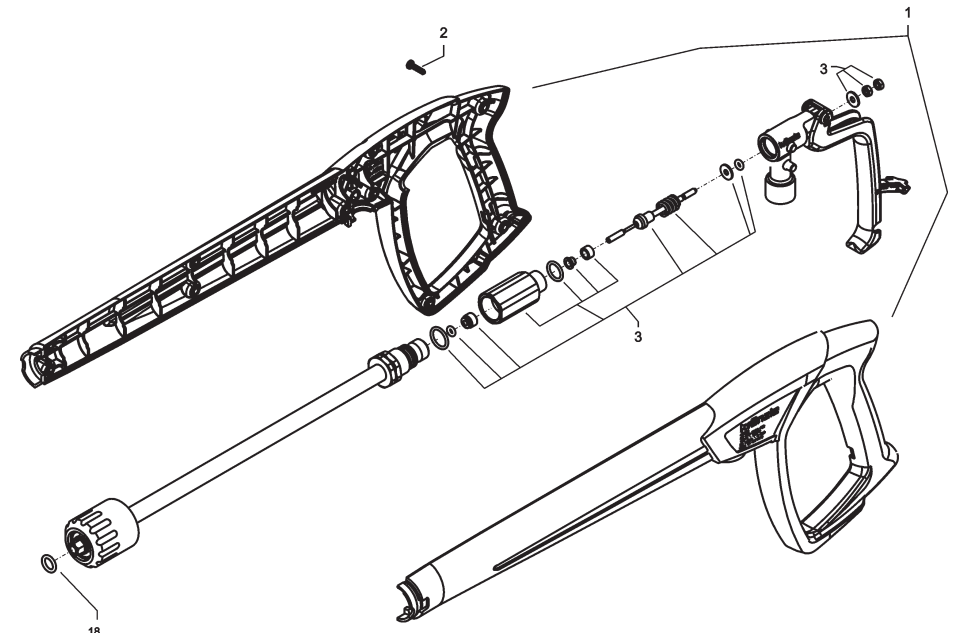

Spare parts list M2000-Gun

No	Description	Qty.	Ord.-No
1	Pistolschale re+li	1	12.450
2	Schraube 3,5 x 14	10	44.525
3	Reparatursatz M2000		12.454
18	O-Ring 9,3 x 2,4	1	13.273

Pistole M2000 12.480

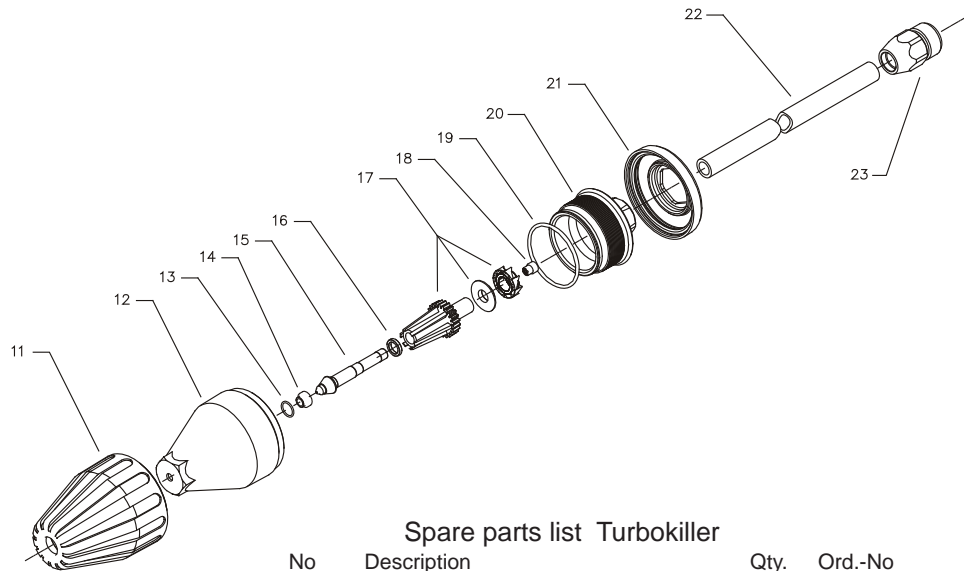

Spare parts list Turbokiller

No	Description	Qty.	Ord.-No
11	Sprühkörperschutz	1	41 528
12	Sprühkörper	1	41 529
13	O-Ring 6,86x178	1	41 521
14	Düsenstanz	1	41 522
15	Düse 055 für B 170 T / 240 T / 270 T	1	41 532
	Düse 045 für B 200 T	1	41 532 1
	Düse 07 für B 230 T	1	41 532 2
16	Ring	1	41 533
17	Rotor	1	41 534
18	Stabilisator	1	41 524
19	O-Ring 41 x 1,78	1	41 538
20	Deckel	1	41 539
21	Deckelschutz	1	41 540
22	Rohr 500 mm lang; bds. R1/4"	1	12 385 1
23	Nippel M22x1,5 x R1/4" IG	1	13 370
	Turbokiller 045 compl. (200T)		41 072 3
	Turbokiller 055 compl. (170T/240T/270T)		41 072 4
	Turbokiller 07 compl. (230T)		41 072 7
	Repair kit Turbokiller 045		41 097 6
	Repair kit Turbokiller 055		41 097 1
	Repair kit Turbokiller 07		41 097 2

Guarantee

The guarantee is only valid for material and manufacturing errors. Wearing does not fall within this guarantee.

The instructions in our operating manual must be complied with. The operating instructions form part of the guarantee. The Guarantee is void if other parts are used than genuine Kränzle accessory parts or genuine Kränzle spare parts.

For high-pressure cleaners sold to the user the guarantee period is 24 month.

For high-pressure cleaners sold for industrial use the guarantee period is 12 month. In the case of a guarantee please contact your dealer or authorized seller delivering accessories and your purchase receipt. You can find them in the internet under www.kraenzle.com.

The guarantee is also void if the machine is used with exceeding the temperature and speed limits, a voltage below the required rating, with less than the required amount of water or with dirty water. Pressure gauge, nozzle, valves, sleeves, high pressure hose and spray equipment are wear parts and are not covered by the warranty.

Inspection report

for KRÄNZLE - High Pressure Cleaners

Regular inspection every 12 months if used professionally!

Appliance No:

Type:

The following must be checked:

1. Safety features

- a) Manometer
- b) Safety valve (pressure control)
- c) Operating pressure
- d) Cut out pressure (max. 10% above operating pressure)
- e) Low pressure with trigger released

2. General condition

- a) High pressure hose
- b) Spray gun
- c) Motor
- d) Oil level

The information in the operating instructions are a part of the inspection

Result of inspection:	Date of inspection:	Faults rectified, Stamp and signature
<input type="text"/>	<input type="text"/>	<input type="text"/>
<input type="text"/>	<input type="text"/>	<input type="text"/>
<input type="text"/>	<input type="text"/>	<input type="text"/>

Excerpt from the Guidelines for Liquid Spray Equipment (ZH 1/46) by the Central Office of the Professional Trade Association.

Inspection:

Liquid spray equipment should be inspected for safe operation by a qualified person whenever necessary, but no less than every 12 months. The maker's or supplier's instructions must be followed. The inspection intervals may be extended if the equipment is not in active use.

In Germany, inspections compliant with the (German) Emission Controls Act may be required for oil and gas-fired equipment, and the owner must arrange for these to be carried out independently of the main inspection.

The results of inspections must be recorded in writing and presented to the respective authorities on demand. There is no set form for these records.

kränzle®

High-pressure-cleaners
Nettoyeurs à haute pression
Hochdruckreiniger



I. Kränzle GmbH
Elpke 97 . 33605 Bielefeld

EC declaration of conformity

We hereby declare,
that the high-pressure models:
Nominal flow

Kränzle B 170,200,230,240,270

B 170T; B 200T: 750 l/h
B 240T; B 270T: 960 l/h
B 230T: 1200 l/h

(techn. documentation available from):

Manfred Bauer, Fa. Josef Kränzle
Rudolf-Diesel-Str. 20, 89257 Illertissen

comply with the following guidelines
and specifications and their amend-
ments for high-pressure cleaners:

Machine guideline 2006/42/EEC
**Specification for electromagnetic com-
patibility 2004/108/EEC**
Outdoor noise directive 2005/88/EC,
Art. 13, High-pressure water jet machines
Appendix 3, part B, chapter 27

Sound power level

measured:
guaranteed:

100 dB (A)
103 dB (A)

Applied conformity evaluation proce-
dures

annex V, noise directive 2005/88/EC

Applied specifications and
standards:

EN 60 335-2-79 :2015
EN 55 014-1 :2006
EN 61 000-3-2 :2014
EN 61 000-3-3 :2013

Bielefeld, den 16.06.2015

Kränzle Josef
(Managing Director)

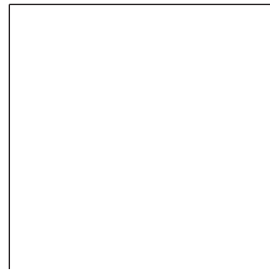

Order n°: 30.250 1

I. Kränzle GmbH

Elpke 97

D - 33605 Bielefeld

Reprint only allowed with the authorization of **kränzle®**
As date of 16.06.2015